

Product datasheet

Dock leveler

ASSA ABLOY DL6010SR

ASSA ABLOY

ASSA ABLOY Entrance Systems

The global leader in
door opening solutions

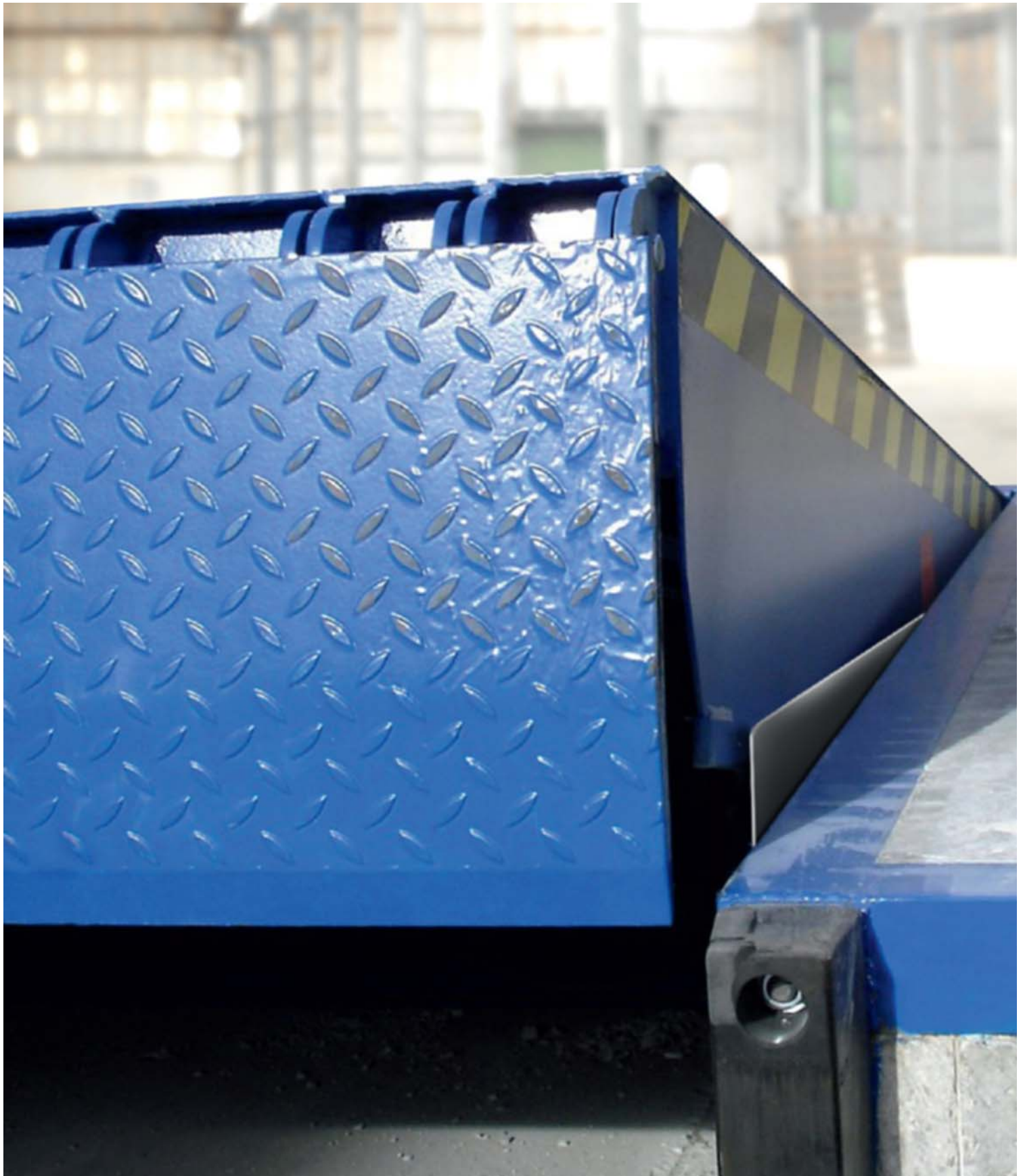

Copyright and Disclaimer Notice

Although the contents of this publication have been compiled with the greatest possible care, ASSA ABLOY Entrance Systems cannot accept liability for any damage that might arise from errors or omissions in this publication. We also reserve the right to make appropriate technical modifications/replacements without prior notice.

No rights can be derived from the contents of this document.

Color guides: Color differences may occur due to different printing and publication methods.

No part of this publication may be copied or published by means of scanning, printing, photocopying, microfilm or any other process whatsoever without prior permission in writing by ASSA ABLOY Entrance Systems.

Copyright © ASSA ABLOY Entrance Systems AB 2006-2017.

All rights reserved.

ASSA ABLOY, Besam, Crawford, Albany and Megadoor as words and logo are trademarks belonging to the ASSA ABLOY Group

Technical facts

Features

Sizes - pit length	1765mm - 3050mm	
Sizes - nominal length	1750mm - 3000mm	
Sizes - pit width	1730mm - 2310mm	
Sizes - nominal width	1700mm - 2250mm	
Vertical working range	Above dock:	0 - 430 mm
	Below dock:	0 - 360 mm
Platform tear plate	Standard:	Thickness: 6 mm (6/8)
	Option:	Thickness: 8 mm (8/10)
Surface treatment:	Standard:	RAL 5010
	Option:	RAL 3002 RAL 6005 RAL 9005 Hot dip galvanised
Control Unit	Leveler control Door control Shelter control Fault & service indicator	

*Other sizes are available on request.

Performance

Load capacity:	60kN (6 tonnes)
Max. point load:	8 mm (8/10)(6,5 N/mm ²)
Motor hydraulic unit:	0,75 kW
Mains supply:	400V 3-phase, 230V 3-phase
Control unit protection class:	950-series IP54
Allowable oil types:	ASSA ABLOY standard hydraulic oil (-20°C - +60°C) ASSA ABLOY low temperature hydraulic oil (-30°C - +60°C) ASSA ABLOY bio hydraulic oil (-20°C - +60°C)
Magnetic valves:	24V/DC 18W S1
Surface treatment paint class 1:	80 µm C2 M acc. DIN EN ISO 12944-2
Surface treatment paint class 3:	160 µm C3 M acc. DIN EN ISO 12944-2
Surface treatment galvanised:	Hot dip 80 µm C4 & C5-I M acc. DIN EN ISO 12944-2

Contents

Copyright and Disclaimer Notice	2
Technical facts	3
Contents	4
1. Description	6
1.1 General	6
1.2 Replacement System	6
1.2.1 Replacement F-Frame System.....	6
1.2.2 Replacement Pit-frame system	8
1.3 Leveler	9
1.3.1 Application.....	9
1.3.2 Mode of operation	9
1.3.3 Overview.....	9
1.4 Swing Lip.....	10
1.4.1 Lip shapes	10
1.4.2 Lip angles	10
1.5 Platform	11
1.5.1 Platform tear-plate thickness	11
1.5.2 Toe guards.....	11
1.5.3 EPDM seal (only with frame F)	11
1.5.4 Slip protection / noise reduction.....	11
1.5.5 Platform insulation.....	11
1.6 Surface.....	12
1.6.1 Painting	12
1.6.2 Hot galvanising.....	12
1.7 Docking control systems	13
1.7.1 950 Docking L SD.....	13
1.7.2 950 Docking LA SD.....	13
1.7.3 950 Docking DL SD	13
1.7.4 950 Docking DLA SD	13
1.7.5 950 Docking LS SD	14
1.7.6 950 Docking LSA SD	14
1.7.7 950 Docking DLS SD.....	14
1.7.8 950 Docking DLSA SD	14
1.8 Equipment.....	15
1.8.1 Buffers.....	15
1.8.2 ASSA ABLOY DE6090E Eye	16
1.8.3 ASSA ABLOY DE6090WC Wheel chock	16
1.8.4 ASSA ABLOY DE6090TLS Traffic light system	16
1.8.5 ASSA ABLOY DE6090DL Dock light Heavy Duty LED	16
1.8.6 Parking guides.....	16
1.8.7 ASSA ABLOY DE6090DI Dock-IN.....	16

2.	Selection guide	18
2.1	Load capacity according to EN 1398	18
2.1.1	Rated load	18
2.1.2	Axle load	18
2.1.3	Dynamic load	18
2.2	Select the load capacity	18
2.2.1	Example	18
2.3	Select the appropriate platform tear plate thickness	18
2.3.1	Handling equipment traffic situation.....	18
2.3.2	Example	18
3.	Specifications	19
3.1	Dimensions.....	19
3.2	Platform thickness.....	19
3.3	Control units	20
3.3.1	Dimensions.....	20
3.3.2	Functions	20
4.	CEN Performance	21
4.1	Safety according to the European Standard EN 1398	21
5.	Building and space requirements	22
5.1	Electrical preparations.....	22
6.	Service	23
	Index	24

1. Description

1.1 General

The ASSA ABLOY DL6010SR swing replacement is an efficient upgrade solution to replace obsolete dock levelers. Based on the existing pit there is a choice of various replacement options that suits the situation best.

The replacement system requires that the existing concrete pit and steel profiles are strong enough to cover the loads of a new leveler.

The replacement F-frame system is designed to weld the leveler directly to the old existing leveler's frame. This system is especially developed for the replacement of existing levelers with a frame on all three sides in an open pit – not only in a closed pit.

The replacement Pit-frame system is designed to take out the old leveler completely and install the new leveler according to the basic principles of a Pit model. This system is especially developed for the replacement of existing Pit model levelers. Only the rear frame is welded to the existing steel profile in the concrete; the front part of the leveler is supported directly by the floor of the closed pit or by strong steel brackets of the open pit.

An ASSA ABLOY expert will carry out the inspection of the pit condition and check the dimensions. This ensures the best possible replacement solution for the obsolete dock leveler.

The ASSA ABLOY DL6010SR swing replacement system meets the standard demands of most loading operations and fully complies with rules and regulations of the European Standard EN 1398. This replacement system is available as a 60kN swingdock leveler.

1.2 Replacement System

1.2.1 Replacement F-Frame System

1.2.1.1 Check the condition of the existing pit

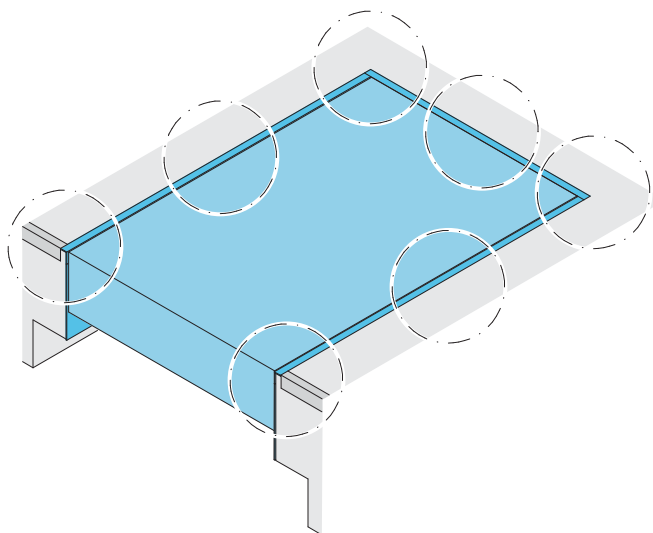

The frame is the leveler's connection point to the building and a rigid support for the leveler. The replacement F-frame system requires that the concrete pit and the old existing frame are strong enough to cover the loads of a new leveler. The F-frame is designed to weld the leveler directly to the existing leveler's frame.

If these requirements are not fulfilled, then the solution is a complete renovation of the concrete pit and the delivery of a new leveler with the T-frame system.

Your expert from ASSA ABLOY will do the visual inspection.

1.2.1.2 Remove existing leveler

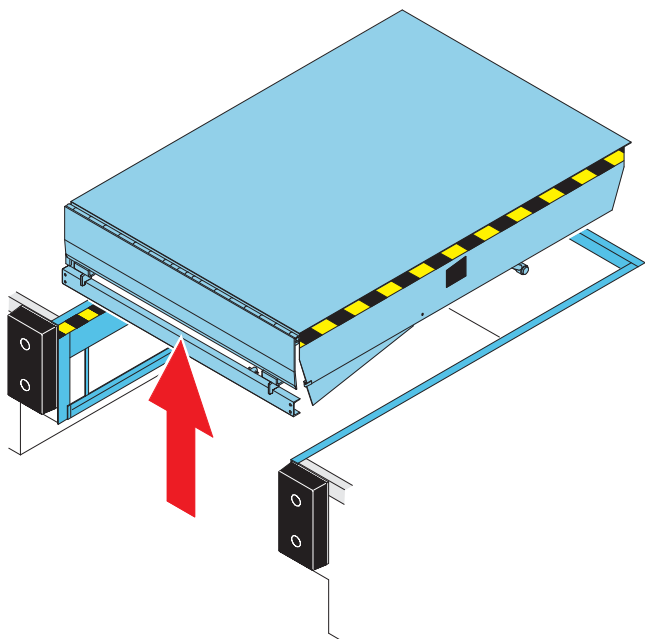

Remove the old leveler. Leave the old leveler's steel frame in the pit.

1.2.1.3 Check the dimensions of the existing pit

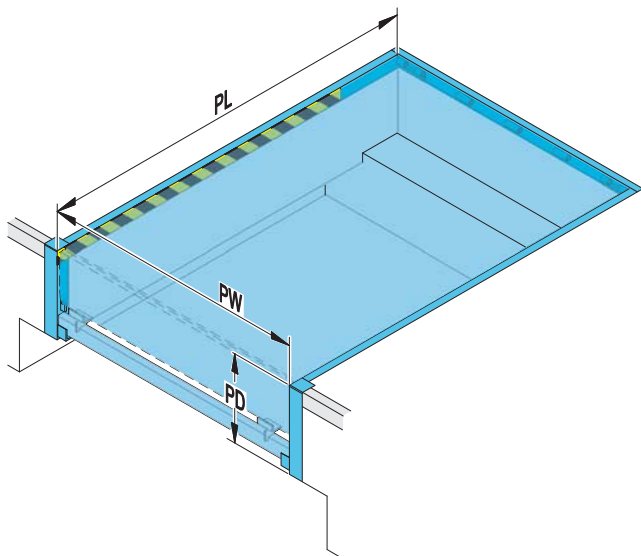

Your expert from ASSA ABLOY will check the exact dimensions.

1.2.1.4 Place new leveler

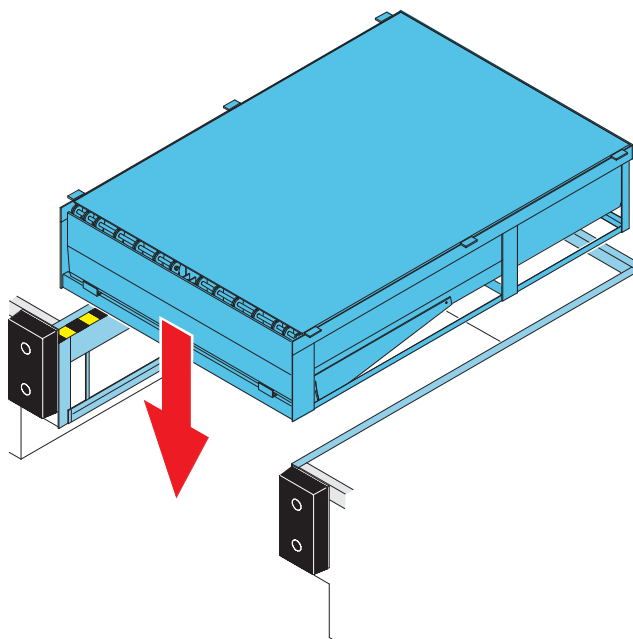

Weld the replacement leveler directly to the old existing leveler's frame on all three sides.

When installed, the front end of the new leveler will not always fit exactly to the existing frame in the pit.

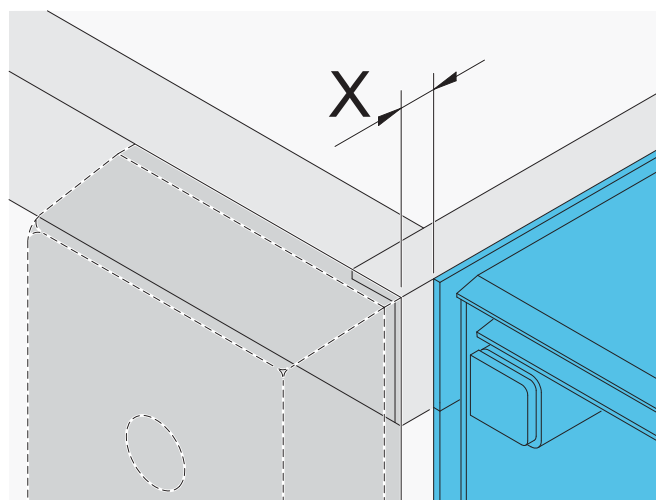

The side frame can be up to 15 mm shorter than the existing frame in the pit.

X = max. 15 mm to ensure that the lip comes far enough into the truck bed.

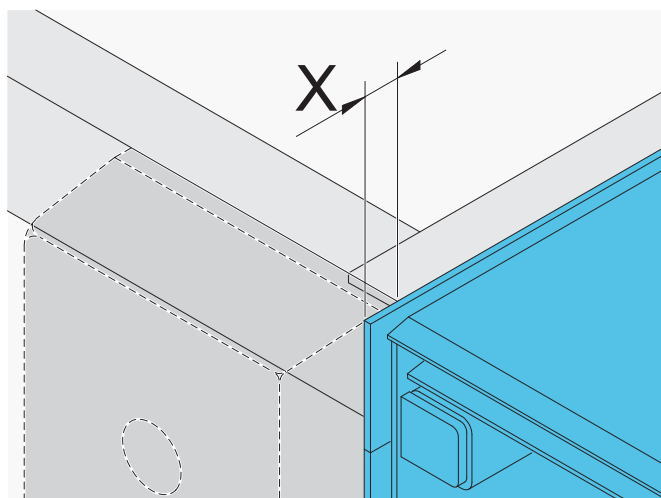

The side frame can be up to 35 mm longer than the existing frame in the pit.

$X = \text{max. } 35 \text{ mm}$ to allow buffers of about 100 mm depth to provide proper protection.

1.2.2 Replacement Pit-frame system

1.2.2.1 Check the condition of the existing pit

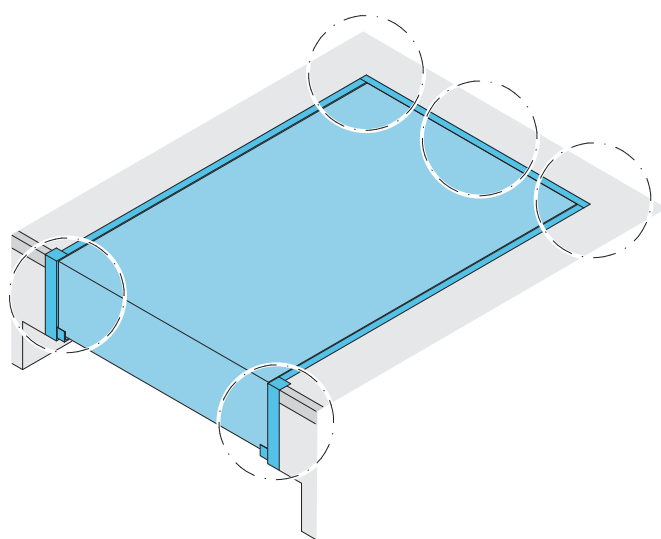

The frame is the leveler's connection point to the building. The replacement Pit-frame system requires that the concrete pit and the old existing steel profile in the concrete are strong enough to cover the loads of a new leveler. The Pit-frame is designed to take out the old leveler completely.

If these requirements are not fulfilled, then the solution is a complete renovation of the concrete pit and the delivery of a new leveler with the T-frame system.

Your expert from ASSA ABLOY will do the visual inspection.

1.2.2.2 Remove existing leveler

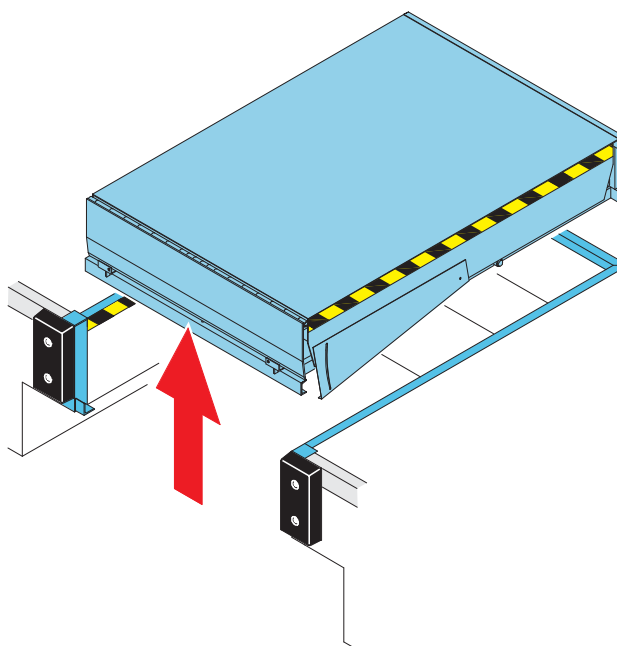

Remove the complete steel structure.

1.2.2.3 Check the dimensions of the existing pit

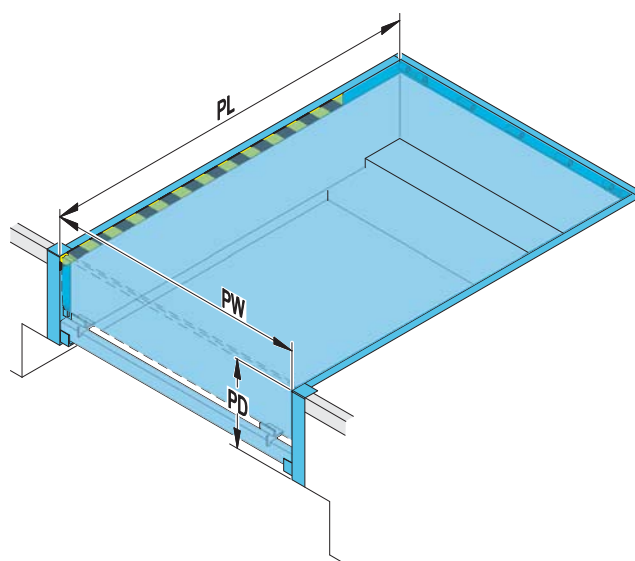

Your expert from ASSA ABLOY will check the exact dimensions.

1.2.2.4 Place new leveler

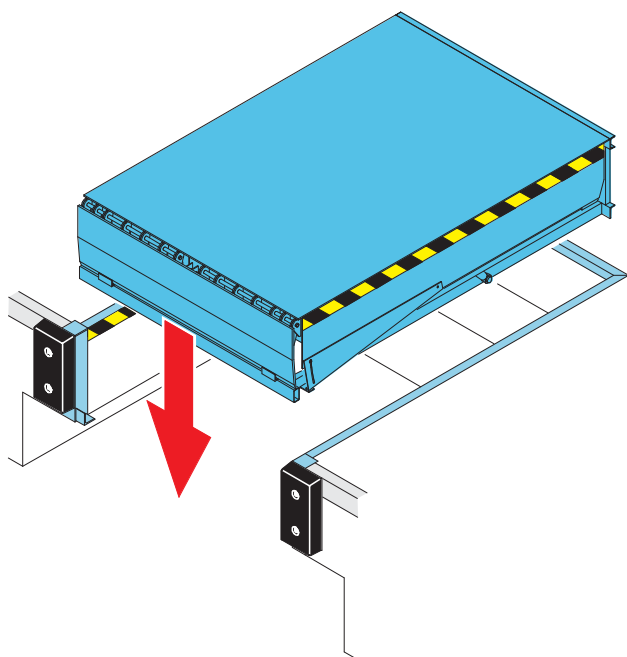

Install the new leveler according to the the basic principles of a Pit model; weld the rear frame to the existing steel profile in the concrete, the front part of the leveler is supported directly by the floor of the closed pit or by strong steel brackets of the open pit.

1.3 Leveler

1.3.1 Application

The ASSA ABLOY DL6010SR swing replacement is the standard solution in general industry applications and easy to operate. The swing lip safely bridges the gap between the ramp and the lorry bed. The ASSA ABLOY DL6010SR swing replacement system meets the standard demands of most loading operations and fully complies with rules and regulations of the European Standard EN 1398.

1.3.2 Mode of operation

The operation of the ASSA ABLOY DL6010SR swing replacement is based on an electro-hydraulic swing lip, controlled by a semi-automatic control unit.

When the dock leveler is raised, the lip swings out and the leveler lowers gently onto the lorry bed. After loading or unloading, the leveler is raised again, the lip swings down and the platform returns to its parking position, i.e. to ramp level.

1.3.3 Overview

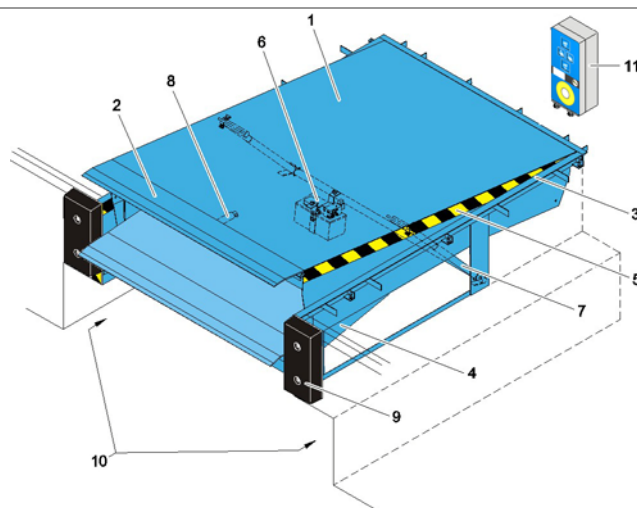

Shown is a leveler with F-frame

- 1 Leveler platform
- 2 Swing lip
- 3 Leveler frame
- 4 Toe guards
- 5 Warning stripes
- 6 Hydraulic unit
- 7 Lift cylinders
- 8 Swing lip cylinder
- 9 Buffers (option)
- 10 Tail lift recess
- 11 Control unit

1.4 Swing Lip

1.4.1 Lip shapes

1.4.1.1 Standard swing lip

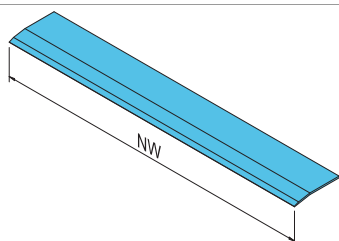

The standard swing lip is a single rectangular lip for use with a fleet of vehicles that is a standard size.

1.4.1.2 Tapered swing lip

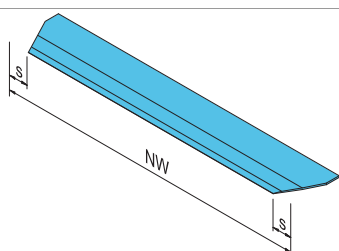

A tapered swing lip ensures that the lip reaches the lorry bed, even when the lorry is not parked in the exact centre position. Avoids damage to the truck and interruptions of the dock-in procedure. $s = 125 \text{ mm}$

1.4.1.3 Fold down segments

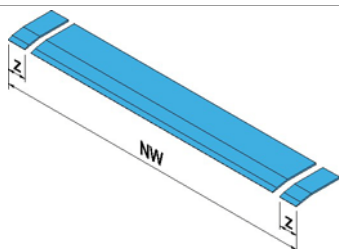

Ensures that the swing lip reaches the lorry bed by folding down one or both outer segments when the lorry is smaller than usual, or not parked in the exact centre position. Avoids damage to the truck and interruption of the dock-in procedure. Only available for 60 kN. $Z = 125 \text{ mm}$

1.4.2 Lip angles

1.4.2.1 Bent lip

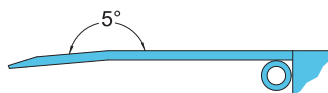

The standard bent steel swing lip ensures smooth transition to a lorry bed both above and below dock level. Avoids tripping hazards according EN 1398.

1.4.2.2 Straight lip

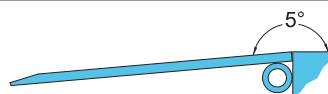

A straight steel swing lip ensures smooth transition when the lorry bed is below or equal to dock level. Avoids tripping hazards according EN 1398.

1.4.2.3 Bevelled lip

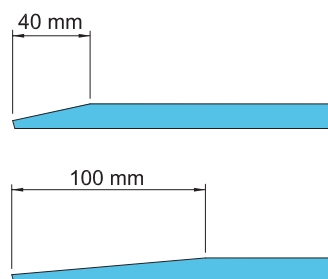

The standard steel lip is 40 mm bevelled. Optionally, the lip can be bevelled 100 mm, designed to provide maximum comfort and smooth transition from the lip.

1.5 Platform

1.5.1 Platform tear-plate thickness

The 6 mm (6/8) tear-plate is designed for loading and unloading with typical 4 wheel pneumatic-tired fork-lift trucks. Alternatively an 8 mm 8/10 tear-plate is available for handling equipment with high point loads, such as electric pallet trucks. However, potential platform deformations do not reduce the functionality of the leveler.

1.5.2 Toe guards

The leveler is as standard equipped with toe guards; steel plates between the platform and the frame. The toe guard prevents the pinching of feet when the leveler is lowered.

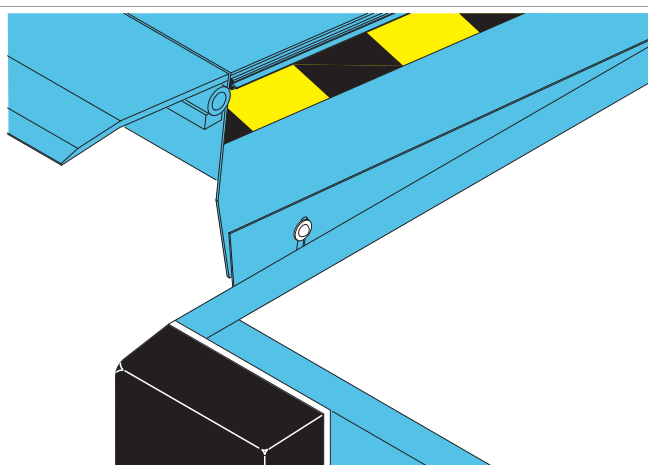

1.5.3 EPDM seal (only with frame F)

To seal the gap between leveler and pit, an EPDM seal can be factory-installed between the flexible platform and frame. By reducing draughts into the building, working conditions improve and energy savings increase.

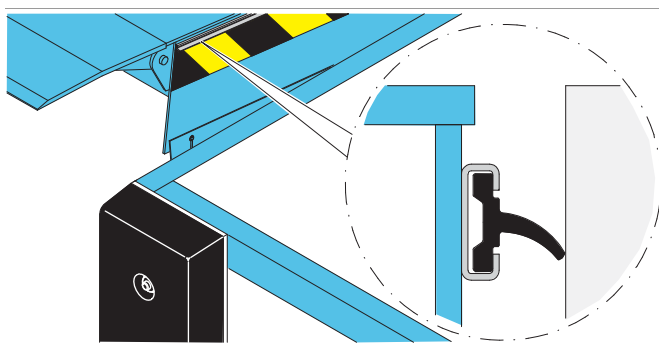

1.5.4 Slip protection / noise reduction

Applying a polyurethane slip protection coating on the lip and platform ensures a durable non-slip and noise reduction surface. The effect is a smooth and comfortable surface for handling equipment that is less receptive to wear and tear. The PU coating material is resistant to impact, to thermal impact and most types of chemicals and it has a high loading capacity.

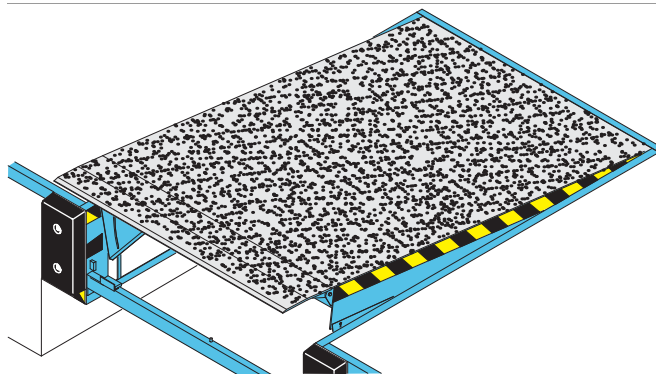

1.5.5 Platform insulation

When the dock leveler is positioned in a bay directly outside the door opening, it can be beneficial to insulate the dock leveler. The insulation counteracts the penetration of incoming heat/cold from outside. To achieve the best results, the dock leveler should also be fitted with an EPDM seal.

The insulation consists of factory-installed insulated panels with a thickness of 40 mm.

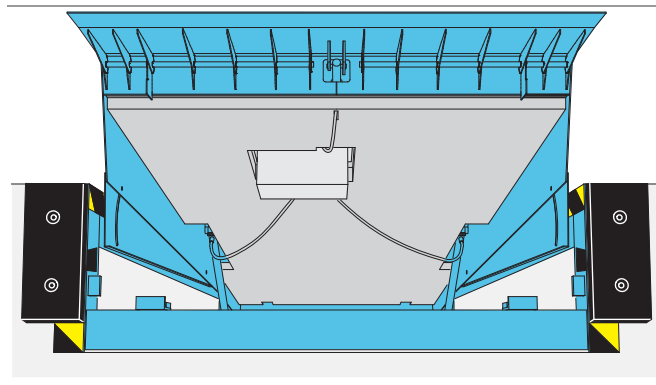

1.6 Surface

1.6.1 Painting

1.6.1.1 Colors

The dock leveler standard finish is painted. The standard color is:



Colours available as option are:

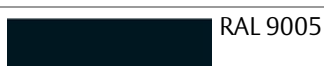

1.6.1.2 Standard paint class

If the dock leveler is to be used in a rural area, the standard finish is:

- Paint class 1; 80 µm factory painted for corrosive category C2 M

1.6.1.3 Paint classes

If the dock leveler is to be used in an urban or industrial atmosphere, or in a coastal area, it may be appropriate to select an alternative paint class with increased resistance to corrosion C3 M.

- Paint class 3; 160 µm factory painted for corrosive category C3 M

1.6.2 Hot galvanising

To increase corrosion protection to C4 for saline coastal areas or C5-I for aggressive or humid atmospheres, the dock leveler can be delivered with hot dip galvanised (80 µm) steel parts.

1.7 Docking control systems

1.7.1 950 Docking L SD



- Hold-to-run button to position the lip on the truck bed.
- Hold-to-run button to put the leveler back in parking position.
- Mains isolator or emergency stop button.
- Interface to incorporate ASSA ABLOY Eye and/or wheel chock.

1.7.3 950 Docking DL SD

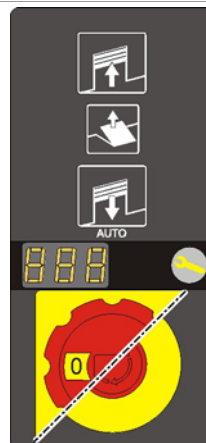

Designed to operate an overhead sectional door in the docking station.

- Hold-to-run button to position the lip on the truck bed.
- Hold-to-run button to put the leveler back in parking position.
- Mains isolator.
- Interface to incorporate ASSA ABLOY Eye and/or wheel chock.

1.7.2 950 Docking LA SD



- Hold-to-run button to position the lip on the truck bed.
- Impulse auto button to put the leveler back in parking position.
- Mains isolator or emergency stop button.
- Interface to incorporate ASSA ABLOY Eye and/or wheel chock.

1.7.4 950 Docking DLA SD

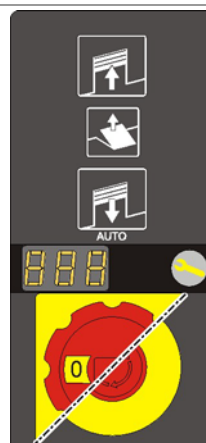

Designed to operate an overhead sectional door and an inflatable shelter in the docking station.

- Hold-to-run button to position the lip on the truck bed.
- Impulse auto button to put the leveler back in parking position.
- Mains isolator or emergency stop button.
- Interface to incorporate ASSA ABLOY Eye and/or wheel chock.

1.7.5 950 Docking LS SD

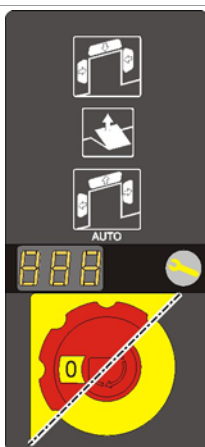

Designed to operate an inflatable shelter in the docking station.

- Hold-to-run button to position the lip on the truck bed.
- Hold-to-run button to put the leveler back in parking position.
- Mains isolator.
- Interface to incorporate ASSA ABLOY Eye and/or wheel chock.
- Designed to operate an inflatable shelter in the docking station.

1.7.7 950 Docking DLS SD

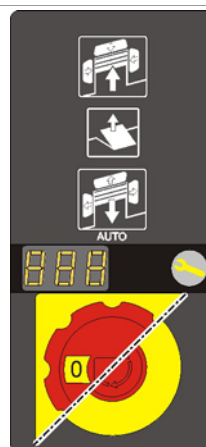

Designed to operate an overhead sectional door and an inflatable shelter in the docking station.

- Hold-to-run button to position the lip on the truck bed.
- Hold-to-run button to put the leveler back in parking position.
- Mains isolator.
- Interface to incorporate ASSA ABLOY Eye and/or wheel chock.
- Designed to operate an overhead sectional door and an inflatable shelter in the docking station.

1.7.6 950 Docking LSA SD

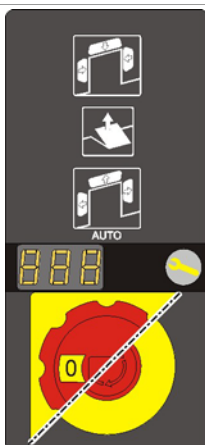

Designed to operate an overhead sectional door and an inflatable shelter in the docking station.

- Hold-to-run button to position the lip on the truck bed.
- Impulse auto button to put the leveler back in parking position.
- Mains isolator or emergency stop button.
- Interface to incorporate ASSA ABLOY Eye and/or wheel chock.
- Designed to operate an inflatable shelter in the docking station.

1.7.8 950 Docking DLSA SD

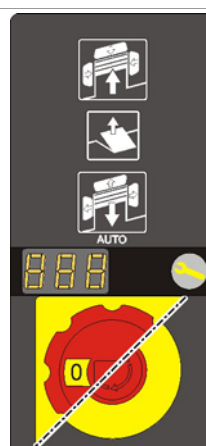

Designed to operate an overhead sectional door and an inflatable shelter in the docking station.

- Hold-to-run button to position the lip on the truck bed.
- Impulse auto button to put the leveler back in parking position.
- Mains isolator or emergency stop button.
- Interface to incorporate ASSA ABLOY Eye and/or wheel chock.
- Designed to operate an overhead sectional door and an inflatable shelter in the docking station.

1.8 Equipment

1.8.1 Buffers

Buffers placed in front of the dock leveler absorb the energy of a vehicle that accidentally or intentionally hits the building. Buffers are available in various sizes, in fixed or moving models, and with rubber finishing or steel plate and spring function.

1.8.1.1 RS

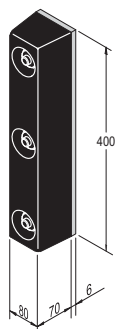

Application

The RS buffer is the economical solution for docking stations where vehicles of equal sizes load and unload.

1.8.1.2 RB

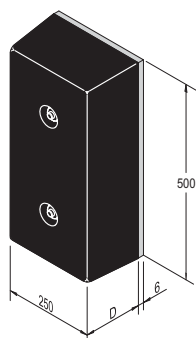

Application

The RB buffer is a large fixed rubber. It is the universal building and vehicle protection solution.

Available depths:

- 90 mm
- 140 mm

1.8.1.3 RB with steel front plate

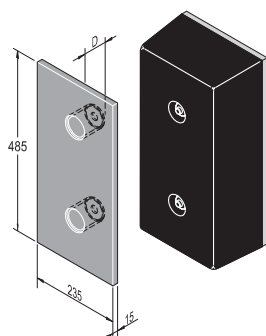

Application

The RB buffer with steel protection front plate increases the building protection and the buffer service life.

Available depths:

- 90 mm
- 140 mm

1.8.1.4 RB with steel front and top plate

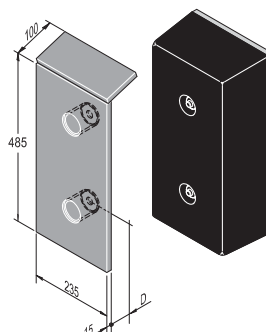

Application

The RB buffer with steel protection front and top plate is designed for vehicles with high lorry beds like interchangeable open bodies and containers.

Available depths:

- 90 mm
- 140 mm

1.8.1.5 EBF

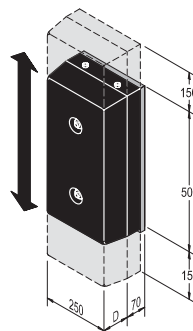

Application

The EBF buffer is the ideal solution for docking stations where vehicles are expected to make notable vertical suspension changes when loading or unloading.

This buffer follows vertical movements of the vehicle.

Available depths:

- 90 mm
- 140 mm

1.8.1.6 EBH

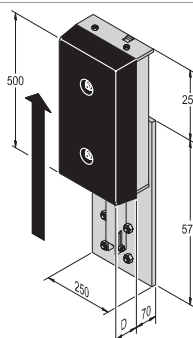

Application

The EBH buffer is the ideal solution for docking stations where vehicles of notable height differences load and unload. This buffer can be vertically adjusted by a 'release device'.

Available depths:

- 90 mm
- 140 mm

1.8.1.7 Steel spring buffer 600

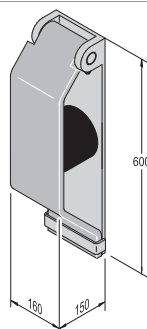

Application

The steel spring buffer is the ideal protector of the ramp as well as the vehicle itself.

1.8.1.8 Steel spring buffer 800

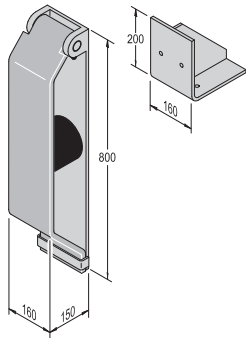

Application

The 800 mm steel spring buffer is designed for applications where vehicles generally are higher than ramp level.

1.8.2 ASSA ABLOY DE6090E Eye

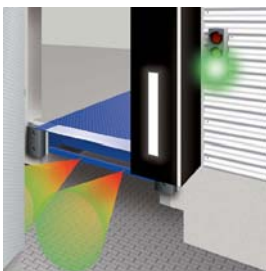

The ASSA ABLOY Eye is an electronic, sensor-based dock-in system, which measures the distance between the vehicle and the building. This makes it easier for the driver to complete the dock-in procedure, but also detects objects or people behind the vehicle.

1.8.3 ASSA ABLOY DE6090WC Wheel chock

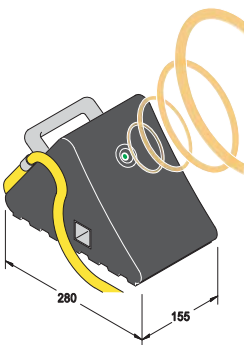

The wheel chock has a sensor to detect the presence and position of the vehicle and is connected to the dock leveler control panel. If no vehicle is detected, the docking station is blocked for safety reasons. Furthermore, the wheel chock prevents the vehicle from moving during loading/unloading.

1.8.4 ASSA ABLOY DE6090TLS Traffic light system



The traffic light system either has a sensor above the dock leveler that measures the presence of the vehicle or it is a wheel chock that detects the vehicle. If there is no vehicle (dock leveler is free), the traffic light inside is red, outside is green. The traffic light can also be combined with a wheel chock, ASSA ABLOY Eye or door/leveler interlocking.

1.8.5 ASSA ABLOY DE6090DL Dock light Heavy Duty LED

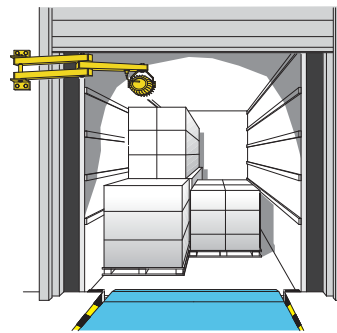

Where dock lights are often a vulnerable object in the docking area, the virtually indestructible Dock Light Heavy Duty LED is the perfect solution to bring light in the truck and docking area. It is designed for the most demanding environments and can withstand possible hard hits from a moving forklift without being damaged.

1.8.6 Parking guides

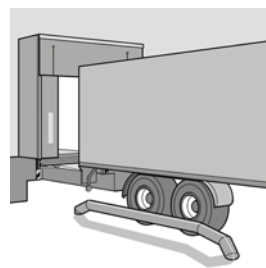

This visual aid makes it easier to park the vehicle and reduces the risk of collision. Especially advantageous for docking stations with wide leveler lips and cushion shelters. Parking guides can be bolted or cast in concrete on the floor before the leveler.

1.8.7 ASSA ABLOY DE6090DI Dock-IN

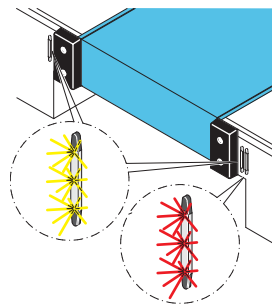

ASSA ABLOY Dock-IN offers a complete line of guide- and traffic lights that align the truck with the docking bay to make the dock-in procedure easy and safe. ASSA ABLOY Dock-IN is based on modern LED technology and stands for high reliability and low energy consumption.

1.8.7.1 Dock-IN White

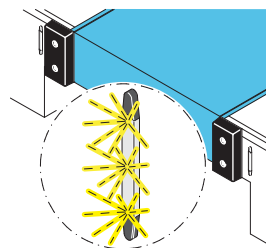

ASSA ABLOY Dock-IN White consists of two white LED light bars. It is designed to help guide a truck to the dock. ASSA ABLOY Dock-IN White offers much more visual aid than white stripes on the shelter or asphalt. Mounted on the wall they are always clearly visible, less exposed to wear and tear and not hidden by dirt and snow!

1.8.7.2 Dock-IN Red

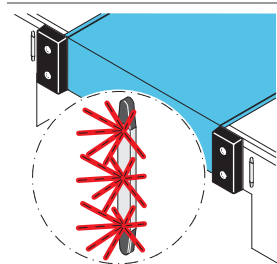

ASSA ABLOY Dock-IN Red is a traffic light system consisting of one red LED light bar, a sensor for truck detection and a traffic light control box. The sensor detects the truck when it is in the right position, very close to the dock. The red LED turns ON to give the signal to the truck driver to break and let the truck roll against the buffer at the lowest speed, without the risk of damage. The system includes interlocking of the loading bay control box functions which are only released when the truck is in place and the red LED is ON.

1.8.7.3 Dock-IN White & Red

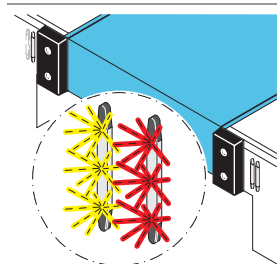

ASSA ABLOY Dock-IN White & Red is the optimum combination of both systems for easy and safe docking. The white LEDs provide the visual target and the red LED positions the truck at the right distance to the dock. The white guiding LEDs turn off when the truck is detected and at the same time the red LED turns ON. When the truck is leaving the white LEDs turn ON. ASSA ABLOY Dock-IN White & Red guide the truck driver in the best possible way for an easy and safe docking.

1.8.7.4 Available Options

- Indication Light Inside, built into the 950 control box A Green LED light on the control box to indicate that the control box functions are released. The operator of the loading bay equipment knows exactly when he can start loading or unloading. The green LED light will help to save energy and to control the complete loading process.

- Second Red LED

A second Red LED bar can be added to have the red LED traffic light on both sides of the docking bay. This is an option for terminals with left and right hand drive international trucks.

- Wheel chock connection

To increase the safety it is possible to connect the ASSA ABLOY wheel chock to the traffic light function ASSA ABLOY Dock-IN Red or ASSA ABLOY Dock-IN White and Red. The control box will be interlocked until the truck is detected and the wheel chock is in place.

Note:

Make sure the LED bars will not be covered by the Dock shelter.

Lowest possible truck is max. 2000 mm below the sensor position.

2. Selection guide

2.1 Load capacity according to EN 1398

The EN 1398 describes 3 key definitions about loads.

2.1.1 Rated load

The rated load is the total weight of the goods, the forklift truck and the driver.



2.1.2 Axle load

Axle loads shall be taken acting over two rectangular contact areas at 1 m lateral distance. These areas shall only apply if the actual conditions do not call for more severe loading. The size of the footprint [mm²] is derived from the wheel load [N] divided by 2 [N/mm²]. The ratio of the rectangular print is W:L = 3:2.

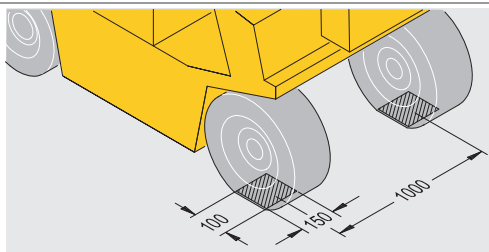

In the drawing measures for a leveler with a load capacity of 100kN or 150kN are shown.

2.1.3 Dynamic load

The dynamic load is the movement of the rated load and is the pressure on the leveler platform caused by the moving forklift truck.



2.2 Select the load capacity

The load capacity of a dock leveler must always be higher than the rated load.

2.2.1 Example

Weight of forklift truck	3600 kg
Weight of goods	1500 kg
Weight of driver	100 kg
Total weight/rated load	5200 kg
Suitable load capacity of the leveler	6000 kg/60kN

2.3 Select the appropriate platform tear plate thickness

The 60kN (6 tonnes) DL6010SR swing replacement is a standard equipped with a tear plate of 6 mm (6/8). Optionally an 8 mm 8/10 tearplate is available.

2.3.1 Handling equipment traffic situation

Each handling-equipment traffic situation creates a certain point load impact on the dock leveler platform depending on the contact area of the wheels. The typical 4 wheel pneumatic-tired forklift trucks have a lower point load impact than electric pallet trucks with small hard wheels.

2.3.2 Example

Vehicle	Rated load	Point load	Tear plate	Load capacity
Roll cage	750 kg	Medium	6 mm	60 kN
Hand pallet truck	3200 kg	High	8 mm	60 kN
Electric pallet truck	3200 kg	High	8 mm	60 kN
Forklift truck	5200 kg	Medium	6 mm	60 kN

3. Specifications

3.1 Dimensions

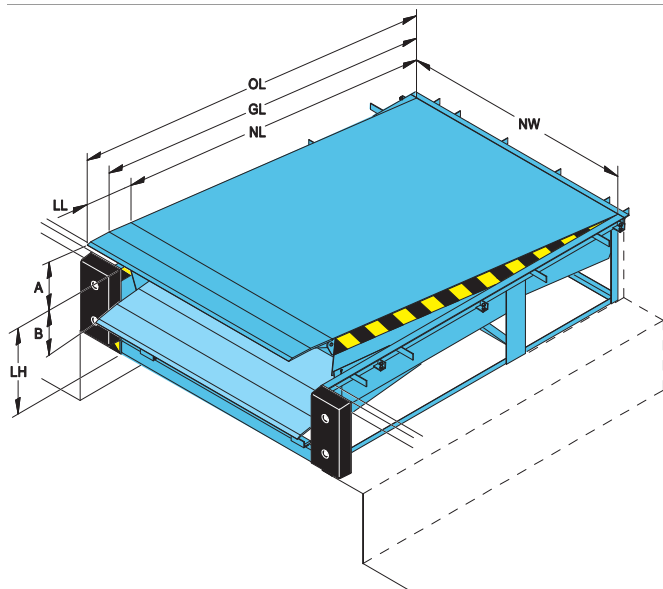

NL	Nominal length
OL	Overall length
GL	Gradient length
NW	Nominal width
LL	Lip length
LH	Leveler height
A	Working range above dock level
B	Working range below dock level

Vertical working range (selected dimensions)

Dimensions		Vertical working range			
		LL 400		LL 500	
NL	LH	A	B	A	B
2000	600	260	280	-	-
	700	290	330	180	360
2500	600	310	270	-	-
	700	390	340	270	360
3000	600	340	265	-	-
	700	400	335	280	290

Leveler dimensions depending on pit dimensions and frame type!

3.2 Platform thickness

Thickness	Max. point load
6 mm (6/8)	1,3 N/mm ²
8 mm 8/10	6,5 N / mm ²

3.3 Control units

3.3.1 Dimensions

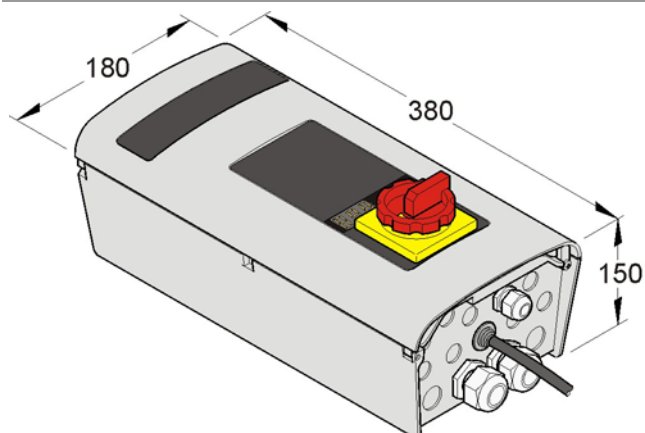

950 Series

3.3.2 Functions

	L SD	LA SD	DL SD	DLA SD	LS SD	LSA SD	DLS SD	DLSA SD
Hold-to-run button	■	■	■	■	■	■	■	■
Impulse auto button		■		■		■		■
Mains isolator	■	■	■	■	■	■		■
Emergency stop button	□	□		□		□		□
400 V	■	■	■	■	■	■		■
230 V	□	□	□	□	□	□	□	□
Maintenance indicator	■	■	■	■	■	■		■
3 Digit display	■	■	■	■	■	■		■
Memory function	■	■	■	■	■	■		■
BUS network interface	□	□	□	□	□	□	□	□
ASSA ABLOY eye	□	□	□	□	□	□	□	□
Wheel chock	□	□	□	□	□	□	□	□
Door control			■	■			■	■
Shelter control					■	■	■	■

■ Standard

□ Option / Available

4. CEN Performance

4.1 Safety according to the European Standard EN 1398

- Emergency Stop Function.
 - Safety valves block lowering movement after max. 6% of the nominal length of the leveler.
 - Two lift cylinders make sure the leveler stops in a horizontal position.
- Free floating position.
- Platform torsion. Lateral deflection of at least 3% of nominal width.
- Toe guards cover gap between platform and pit in leveler's highest position.
- Working range gradient max. 12,5% (~7°).
- Warning stripes on side plates and on frame (black/yellow).

5. Building and space requirements

5.1 Electrical preparations

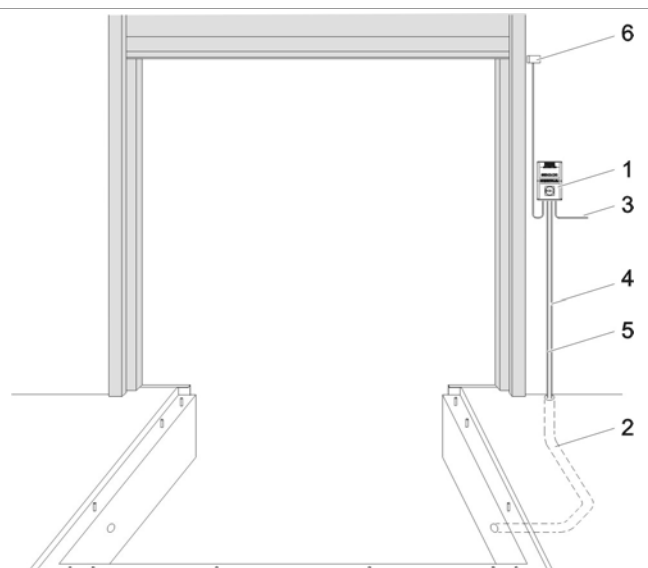

1	Control unit (included in the delivery)	
2	Conduit for wiring internal diameter 70, angles <math><45^\circ</math> (by others)	
3	Mains supply:	3/N/PE AC 50 Hz 400V 3-phase, 230V 3-phase
	Mains fuse:	D0 10 A gL
	Motor power:	0,75kW
4	Cable:	7 x 0,75 mm ²
5	Motor cable:	4 x 1,5 mm ²
6	Optional safety switch on sectional door to disable leveler when door is closed*	

*Non standard

6. Service

Preventive Maintenance Program and Modernization Services

As your entrances are part of your business flow, there's every reason to keep them working well. ASSA ABLOY Entrance Systems offers you a maintenance and modernization expertise to rely on. Our Maintenance Programs and Modernization Services are backed by a extensive expertise for all types of industrial door and docking systems, independent of brand. At your disposal is a team of dedicated expert technicians, proven through decades of maintenance, service and satisfied customers.

Preventive Maintenance Programs

Minimizing lost time, lost energy and unexpected hassle is our team's constant objective. Our service organization can support you 24/7 in maintaining all industrial door and docking systems, independent of brand. If you want to be one step ahead of break-downs, explore our portfolio of Pro-Active Care plans. Naturally, we also offer entrance upgrades to suit your specific wishes and business needs.

Pro-Active Care - Maintenance plans to fit your business

Regular maintenance can extend the lifetime of your equipment and help prevent unexpected problems. Our technician arrives on-site equipped with the knowledge and tools to service all automatic entrances, independent of brand.

- **Pro-Active Bronze**

The base on which all Pro-Active Plans are built provides the security of knowing that your equipment is regularly inspected and certified for safety, as well as performing optimally. It includes a number of planned on-site visits depending on your needs. Any unplanned service calls required during the term of the contract (including labor, travel and parts) are billed at special Pro-Active Care prices.

- **Pro-Active Silver**

This plan provides all the benefits of Pro-Active Bronze with the added advantage of labor and travel being included for service calls during regular business hours. The only additional charge would be for any parts that may be needed throughout the term of the contract.

- **Pro-Active Gold**

This plan provides the ultimate protection for your automatic entrance investment. It includes all the benefits of Pro-Active Silver, plus replacement of any parts required during an unplanned repair or planned maintenance visit. Pro-Active Gold is an excellent way to budget your automatic door expenses annually.

- **Pro-Active Tailor-Flex**

Our most flexible maintenance and service offering. The Pro-Active Care plan is designed by you, our customer. The plan allows you to balance your maintenance expenses against your real-world budget and presents the option to add or delete a number of maintenance elements to suit your budget goals, while meeting your overall performance and safety needs.

Modernization

Your entrances are a long-term investment, from which you always want the best. Products develop over time, so do regulations and your business. Let us help you increase energy savings and meet today's standards. We provide advice and modernization kits for outdated installations, ensuring your investment meet requirements and performs optimally for many more years to come.

Re-Active Service		Pro-Active Care				
		Pro-Active Bronze	Pro-Active Silver	Pro-Active Gold	Pro-Active Tailor Flex	
		○	○	○	●	Other customized requests such as Response Time, Performance InfoPack and Advanced User Training
		○	○	●	○	Replacement of worn parts according to preventive Consumable Exchange Program
		○	○	●	○	Replacement of spare parts on breakdowns
		○	●	●	○	Travel and labor for additional call-out visits
		●	●	●	●	Preventive maintenance visits 1-4 times per year
		●	●	●	●	Travel and labor for preventive maintenance visits
		●	●	●	●	Response time and priority on call-outs <24h
		●	●	●	●	Preventive planned maintenance that meets the most demanding standards in the market
	●	●	●	●	●	Safety and quality checks according to applicable regulations and norms. Documentation of test results provided
●	●	●	●	●	●	Documentation of equipment status, assessment and service provided, all generated on site
●	●	●	●	●	●	Highly trained professional technicians with extensive knowledge, state-of-the-art tools and the right spare parts*
●	●	●	●	●	●	Dedicated Professional Customer Care Hotline
Corrective	SafetyCheck	Pro-Active Bronze	Pro-Active Silver	Pro-Active Gold	Pro-Active Tailor Flex	

● = Included as standard
 ○ = Available at special prices
 * Well-stocked service vehicles with genuine and new spare parts

Index

Numerics

950 Docking DL SD	13
950 Docking DLA SD	13
950 Docking DLS SD	14
950 Docking DLSA SD	14
950 Docking L SD	13
950 Docking LA SD	13
950 Docking LS SD	14
950 Docking LSA SD	14

A

Application	9
ASSA ABLOY DE6090DI Dock-IN	16
ASSA ABLOY DE6090DL Dock light Heavy Duty LED	16
ASSA ABLOY DE6090E Eye	16
ASSA ABLOY DE6090TLS Traffic light system	16
ASSA ABLOY DE6090WC Wheel chock 16	16
Available Options	17
Axle load	18

B

Bent lip	10
Bevelled lip	10
Buffers	15
Building and space requirements	22

C

CEN Performance	21
Check the condition of the existing pit 6,	8
Check the dimensions of the existing pit	7, 9
Colors	12
Control units	20
Copyright and Disclaimer Notice	2

D

Description	6
Dimensions	19, 20
Dock-IN Red	17
Dock-IN White	16
Dock-IN White & Red	17
Docking control systems	13
Dynamic load	18

E

EBF	15
EBH	15
Electrical preparations	22
EPDM seal (only with frame F)	11
Equipment	15
Example	18

F

Features	3
Fold down segments	10
Functions	20

G

General	6
---------------	---

H

Handling equipment traffic situation	18
Hot galvanising	12

L

Leveler	9
Lip angles	10
Lip shapes	10
Load capacity according to EN 1398	18

M

Mode of operation	9
-------------------------	---

O

Overview	9
----------------	---

P

Paint classes	12
Painting	12
Parking guides	16
Performance	3
Place new leveler	7, 9
Platform	11
Platform insulation	11
Platform tear-plate thickness	11
Platform thickness	19

R

Rated load	18
RB	15
RB with steel front and top plate	15
RB with steel front plate	15
Remove existing leveler	7, 8
Replacement F-Frame System	6
Replacement Pit-frame system	8
Replacement System	6
RS	15

S

Safety according to the European Standard EN 1398	21
Select the appropriate platform tear plate thickness	18
Select the load capacity	18
Selection guide	18
Service	23
Slip protection / noise reduction	11
Specifications	19
Standard paint class	12
Standard swing lip	10
Steel spring buffer 600	15
Steel spring buffer 800	16
Straight lip	10
Surface	12
Swing Lip	10

T

Tapered swing lip	10
Technical facts	3
Toe guards	11

ASSA ABLOY Entrance Systems is a leading supplier of entrance automation solutions for the efficient flow of goods and people. Building on the long-term success of the Besam, Crawford, Albany and Megadoor brands, we offer our solutions under the ASSA ABLOY brand. Our products and services are dedicated to satisfying end-user needs for safe, secure, convenient and sustainable operations.

ASSA ABLOY Entrance Systems is a division of ASSA ABLOY.

assaabloyentrance.com



ASSA ABLOY Entrance Systems

assaabloyentrance.com